

形名  
D13VG(1/2)

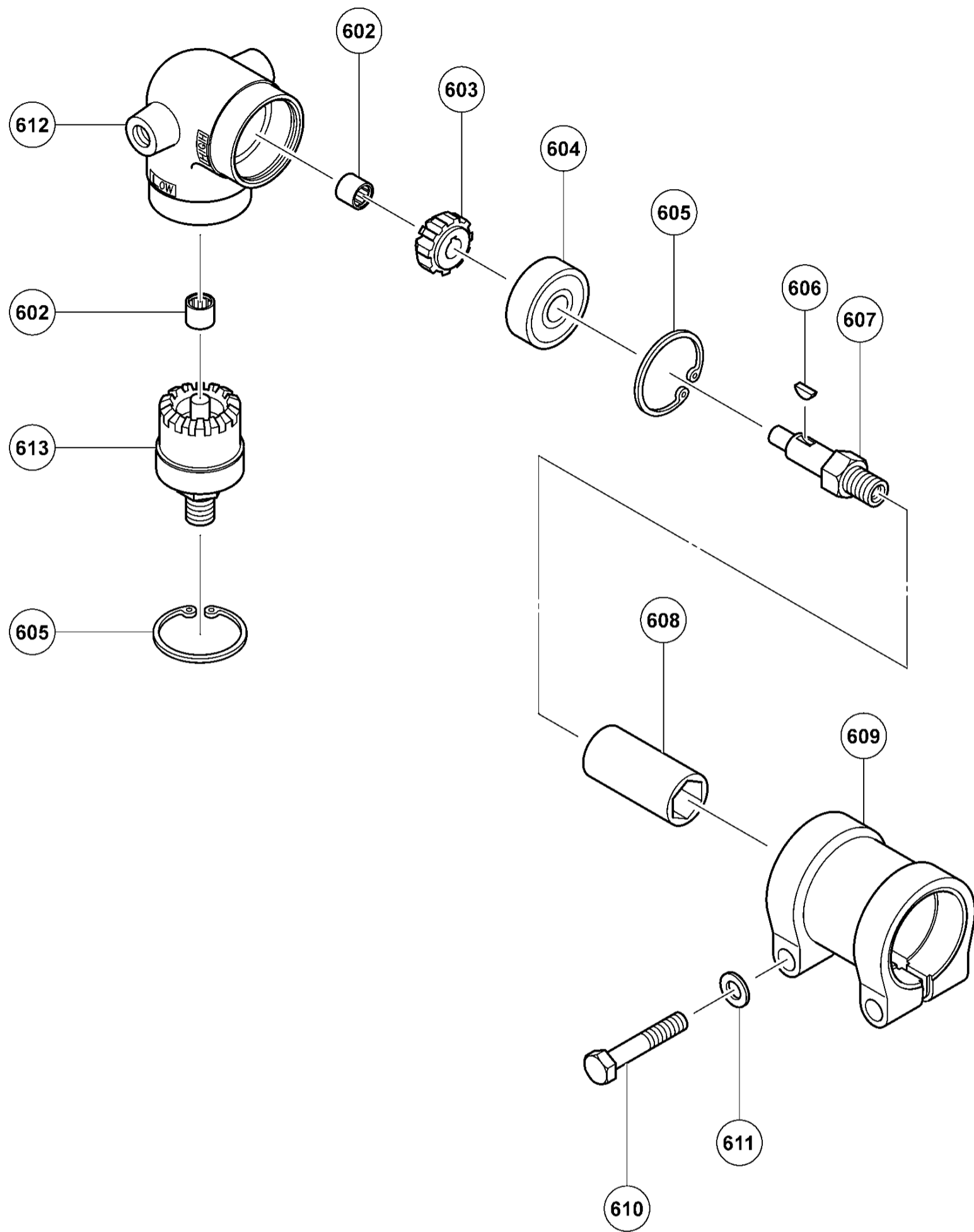

# 13MM DRILL D 13VG

Item No.	Code No.	Description	No. used	Remarks
1	311959	SPECIAL SCREW (LEFT HAND) M6X23	1	
2	319527	CHUCK WRENCH 13VLR-J	1	
3	950288	VINYL BAND	1	
4	319303	DRILL CHUCK 13VLR-J	1	INCLUD.2
4	319304	DRILL CHUCK 13VLRD-N (W/O CHUCK WRENCH)	1	
5	319346	SPINDLE (A)	1	
6	948001	RETAINING RING FOR D32 HOLE	1	
7	6002VV	BALL BEARING 6002VVCMP2L	1	
8	939544	RETAINING RING FOR D15 SHAFT (10 PCS.)	1	
9	305701	TAPPING SCREW (W/FLANGE) D5X60	2	
10	319345	GEAR COVER (A)	1	
11	627VVM	BALL BEARING 627VVC2PS2L	1	
12	319305	FINAL GEAR (C)	1	
13	319548	SECOND PINION (C)	1	
14	319544	FIRST GEAR	1	
15	606ZZM	BALL BEARING 606VVC2	1	
16	316458	TAPPING SCREW D5X40 (BLACK)	1	
17	319344	INNER COVER	1	
18	608DDM	BALL BEARING 608DDC2PS2L	1	
19	360543U	ARMATURE ASS'Y 110V-120V	1	INCLUD.18,23,24
*19	360543E	ARMATURE 220V-230V	1	
*19	360543F	ARMATURE 240V	1	
20	319329	FAN GUIDE	1	
21	981421	HEX. HD. TAPPING SCREW D4X55	2	
22	340486E	STATOR 220V	1	
22	340494C	STATOR 120V	1	
*22	340504E	STATOR 230V-240V	1	
23	982631	WASHER (A)	1	

Item No.	Code No.	Description	No. used	Remarks
24	608VVM	BALL BEARING 608VVC2PS2L	1	
25	319328	HOUSING	1	
26		NAME PLATE	1	
27	319331	HANDLE (B)	1	
28	303694	TAPPING SCREW (W/FLANGE) D4X35 (BLACK)	2	
29	301653	TAPPING SCREW (W/FLANGE) D4X20 (BLACK)	1	
30	319332	GRIP COVER	1	
31	319337	SCREW (PLASTIC TIE) D4X25	2	
32		HITACHI LABEL	1	
33	319330	HANDLE (A)	1	
34	955203	BRUSH HOLDER	2	
35	319341	INTERNAL WIRE (BLUE) 86L	1	FOR USA,CAN,HKG
35	320197	CHOKE COIL (BLUE) 220V- 240V	1	FOR AUS,NZL,EUROPE,CHN
36	999041	CARBON BRUSH (1 PAIR)	2	
37	319340	INTERNAL WIRE (BROWN) 86L	1	FOR USA,CAN,HKG
37	320196	CHOKE COIL (BROWN) 220V-240V	1	FOR AUS,NZL,EUROPE,CHN
38	316166	PUSHING BUTTON	1	
39	319302	SWITCH (1P SCREW TYPE) W/LOCK	1	FOR USA,CAN
39	320195	SWITCH (1P SCREW TYPE) W/LOCK	1	FOR AUS,NZL,EUROPE,CHN
40	984750	TAPPING SCREW (W/FLANGE) D4X16	2	
41	937631	CORD CLIP	1	
42	981373	TUBE (D)	2	FOR CORD
43	953327	CORD ARMOR D8.8	1	FOR CORD
44	500240Z	CORD	1	(CORD ARMOR D8.8) FOR USA,CAN
44	500468Z	CORD	1	(CORD ARMOR D8.8) FOR CHN
*44	500439Z	CORD	1	(CORD ARMOR D8.8) FOR AUS,NZL
*44	500247Z	CORD	1	(CORD ARMOR D8.8) FOR

Item No.	Code No.	Description	No. used	Remarks
				NOR,DEN,SWE,FIN
*44	500409Z	CORD	1	(CORD ARMOR D8.8) FOR EUROPE
*44	500447Z	CORD	1	(CORD ARMOR D8.8) FOR SUI
*44	500487Z	CORD	1	(CORD ARMOR D8.8) FOR BRA
*44	500435Z	CORD	1	(CORD ARMOR D8.8) HKG
45	320198	NOISE SUPPRESSOR	1	EXCEPT FOR USA,CAN,HKG
		STANDARD ACCESSORIES		
501	981205	SIDE HANDLE FOR M10	1	
502A	319550	HANDLE JOINT	1	
503A	319543	CASE	1	
		OPTIONAL ACCESSORIES		
601	319528	ANGLE ATTACHMENT ASS'Y	1	INCLUD.603-614
602	670714	NEEDLE BEARING (HK0810)	2	
603	986149	PINION	1	
604	6301VV	BALL BEARING 6301VVCMP2L	1	
605	986147	RETAINING RING FOR D37 HOLE	2	
606	932819	WOODRUFF KEY 3X10	1	
607	986146	SPINDLE	1	
608	986143	COUPLING	1	
609	986142	JOINT SLEEVE	1	
610	949632	BOLT M8X45 (10 PCS.)	2	
611	949426	WASHER M8 (10 PCS.)	2	
612	986144	ANGLE HEAD ASS'Y	1	INCLUD.602
613	986156	SPINDLE AND GEAR SET	1	
614	949168	WRENCH 13/17MM	1	
615	317676	HOOK (A)	1	